

SwitchPilot V2.0

Instruction Manual

4. Edition, December 2017

SwitchPilot V2.0
SwitchPilot Extension V1.0



1. Declaration of conformity	3	6.6.2. Wiring a motor drive.....	12
2. WEEE delaration	4	6.6.3. LGB® motor drive.....	13
3. Important notes – Please read this chapter first ..	4	6.6.4. Polarizing electric frogs	13
4. How this manual will help you	5	7. Decoder settings (programming)	14
5. Introduction – The SwitchPilot family	5	7.1. Changeable decoder settings.....	14
5.1. Members of the SwitchPilot family.....	5	7.1.1. Configuration Variables (CV).....	14
5.1.1. SwitchPilot overview	5	7.1.1.1. Standardization regarding NMRA.....	14
5.1.2. SwitchPilot V2.0.....	5	7.1.1.2. Bits und Bytes	14
5.1.3. SwitchPilot Extension	6	7.2. Programming with DCC systems.....	15
5.2. Features.....	6	7.2.1. Programming on the programming track	15
5.2.1. Operational modes	6	7.2.1.2. Connecting to the programming track	15
5.2.1.1. k83 mode.....	6	7.2.2. Programming on the main track	16
5.2.1.2. k84 mode.....	6	7.3. Programming with Märklin® central stations	16
5.2.1.3. User mode	6	7.4. Programming with the ESU LokProgrammer	16
5.2.2. Transistor outputs	6	8. Address settings	17
5.2.3. Servo outputs	7	8.1. Turnout numbers	17
5.2.3.1. Conventional servos.....	7	8.2. Decoder address	17
5.2.3.2. Digital servos	8	8.2.1. Schedule of turnout numbers and addresses.....	17
5.2.3.3. ESU servo motor	8	8.3. Factory settings	20
5.2.4. Feedback inputs.....	8	8.4. Programming addresses with programming button.....	20
6. Connection to the digital system	8	8.4.1. First address for outputs 1 – 4	20
6.1. Connecting elements of the SwitchPilot.....	8	8.4.2. Second address for outputs 5 - 6	20
6.2. Power supply from the digital system.....	9	9. Parameters of the transistor outputs	20
6.3. Separate power supply.....	9	9.1. Configuration of output with variable duration (k83)..	20
6.4. Wiring of transistor outputs	10	9.2. Output configuration to pulsed output.....	21
6.4.1. Connecting double-coil solenoids	10	9.3. Configuration of an output for PECO solenoid drives..	21
6.4.2. Wiring daylight signals and light bulbs or LEDs	10	9.4. Configuration for continuous operation (k84).....	21
6.5. Wiring a servo.....	11	9.5. Configuring the „zoom“-effect	21
6.6. Wiring feedback contacts	11	10. Features of servo outputs	21
6.6. Wiring the SwitchPilot Extension.....	12	10.1. Configuration of servo end position „A“	21
6.6.1. Relay outputs.....	12	10.2. Configuration of servo end position „B“	21
		10.3. Configuration of servo speed.....	21
		10.4. Disabling the pulse signal and power supply	22

11. RailCom®	22
11.1. How to activate RailCom®	22
11.2. How to read out CVs with RailCom® and ESU ECoS 22	22
11.3. Feedback of turnout position with the ECoS	23
12. Options for SwitchPilot Extension	24
12.1. Time of switching	24
12.2. Assignment of Relays	24
13. Decoder reset	24
13.1. With DCC systems	24
13.2. With programming button.....	24
15.3. With ESU LokProgramer.....	24
16. Support and assistance	25
15. Technical data.....	26
15.1. Technical data SwitchPilot V2.0	26
15.2. Technical data SwitchPilot Extension	26
20. List of all supported CVs.....	27
22. Warranty certificate.....	31

1. Declaration of conformity

We, ESU electronic solutions ulm GmbH & Co. KG, Edisonallee 29, D-89231 Neu-Ulm, Germany, declare in sole responsibility that the product

Product description:

SwitchPilot, SwitchPilot Extension,

Part number: 51820, 51801

complies with all relevant regulations of the Directive for Electromagnetic Compatibility (2004/108/EG). The following harmonised standards have been applied:

EN 55014-1:2006 + A1:2009: Electromagnetic Compatibility - requirements for household appliances, electric tools, and similar apparatus - Part 1: Emission - Product

EN 55014-2:1997 + A1:2001 + A2:2008: Electromagnetic Compatibility - Requirements for household appliances, electric tools, and similar apparatus - Part 2: Immunity - Product family standard.

Copyright 1998 - 2017 by ESU electronic solutions ulm GmbH & Co KG. Electrical characteristics and dimensions are subject to change without prior notice. All rights reserved. ESU might not be held responsible for any damage or consequential loss or damage caused by inappropriate use of the product, abnormal operating conditions, unauthorized modifications to the products etc.

Not suitable for children under 14 years of age. Inappropriate use may result in injury due to sharp points and edges.

Märklin® and mfx® is a registered trademark of the company Gebr. Märklin® and Cie. GmbH, Göppingen, Germany. RailCom is a registered trademark of the company Lenz Elektronik GmbH, Giessen, Germany.

All the other trade marks are owned by their respective right holders. ESU electronic solutions ulm GmbH & Co. KG continues to develop the products according to the company's politics. Therefore, ESU reserves the right to carry out changes and improvements on the products listed in this manual at any time and without any advanced note.

Duplications and reproductions of this documentation are strictly forbidden and need to be allowed by ESU in writing.

2. WEEE delaration

Disposal of obsolete electrical and electronic equipment (as practised in the European Union and other European countries with dedicated collection systems).



This mark on the product, the packaging or the relevant documentation indicates that this product must not be treated like household waste. Instead this product should be disposed of at a suitable collection point for recycling of electrical and electronic appliances. Thus you contribute to avoid negative impact on the environment and people's health that could be caused by inappropriate disposal. Recycling of materials contributes to preserve our natural resources. For more information regarding recycling of this product, please contact your local administration, your waste collection service or the dealer / shop where you purchased this product.

3. Important notes – Please read this chapter first

We congratulate you on your purchase of an ESU Switch Pilot decoder. This manual will guide you step by step through the features of the Decoder.

Important warning:

Please read this manual carefully. Although the SwitchPilot has been designed as a robust device an incorrect connection may lead to faults or even to the destruction of the device. Avoid any “costly” experiments.



- The Switch Pilot is exclusively intended for use with model train layouts only. It may only be operated with the components listed here. Any other use is not permitted.
- Any wiring has to be carried out while power is disconnected.
- Any power supply must be protected by a fuse or circuit breaker to avoid any potential hazards such as burning cables in case of a short circuit. Only use transformers specifically designed for model trains that bear the VDE/EN marks.
- Never operate the SwitchPilot unattended. The SwitchPilot is not a (children's) toy.
- Adhere to the wiring principles as outlined in this manual for wiring any external components. Other circuitry may cause damage to the SwitchPilot.
- SwitchPilot is not water proof. It is not intended for outside use. If you use this product for exterior applications you do so at your own risk.
- Do not attempt to open your SwitchPilot module. Improper treatment may cause damage or destruction.

Introduction - The SwitchPilot family

4. How this manual will help you

This manual was divided into a few chapters, which will gradually show you how to operate the SwitchPilot products.

Chapter 5 includes an overview of the features of the single SwitchPilot decoders.

In chapter 6 we deal with the connection of your layout.

If you wish to adjust the factory settings of your decoder individually, just do so. In chapter 7 - 11, you will find detailed explanations about which settings are possible and how you can change them.

Statements about technical data can be found in chapter 15 as well as a list of all CVs assisted, if necessary.

By using the LokProgrammer, a new firmware file can be downloaded to the SwitchPilot any time.

5. Introduction - The SwitchPilot family

5.1. Members of the SwitchPilot family

The ESU SwitchPilot decoders are especially optimized for stationary operation on your layout. Not matter if you wish to activate turnouts, signals, magnetic un-couplers, light bulbs and other stationary loads or even if you prefer a „state of the art servo motor: One of the SwitchPilot decoders will be quite useful for you, for sure.

The SwitchPilot decoders can be supplied with power either from the digital system or from an external DC-power source. Due to an installed full bridge rectification and backup memory you can do without any additional „power modules“.

All SwitchPilots are multi protocol capable and therefore can either be operated with command stations as per the Märklin®-Motorola® system (e.g.: 6021, Central Station®) or with DCC compliant command stations.

SwitchPilot Decoders are able to control all current DCC programming modes and can be set up either on the main track or the programming track. Thanks to RailCom® it is also possible to read

out data on the main track. Some of the SwitchPilot decoders can be easily set up via a three-button, LED input unit.

By using the LokProgrammer, a new firmware file can be downloaded to the SwitchPilot any time.

SwitchPilot decoders are shipped in a robust body and stand out due to their excellent price-performance ratio.

5.1.1. SwitchPilot overview

	SwitchPilot V2.0	SwitchPilot Servo V2.0
DCC mode		Ok
Motorola mode	Ok	Ok
DCC programming	Ok	Ok
4 double transistor outputs	je 1,5A	-
LED Monitor for outputs	Ok	-
2 servo outputs	Ok	-
4 servo outputs	-	Ok
Feedback input	Ok	-
RailCom®	Ok	Ok
Input unit	-	Ok
Updatable	Ok	Ok

5.1.2. SwitchPilot V2.0

The SwitchPilot is a universal decoder for users who mainly have double-solenoid motors installed, but would like to test the servo technology. Hence the SwitchPilot has four outputs (1-4) for switching of up to 4 double-solenoid accessories (e.g. switches) or 8 accessories like uncouplers or light functions. Each output can be programmed individually for continuous or pulsed output with variable pulse duration or blinking. Thus it is possible to connect light bulbs or LEDs without any additional relays. Automatic fading assures prototypical run-up and shut-down of signal lamps. In addition two commercially available RC-servos for hobby applications may be wired directly to the SwitchPilot (outputs 5 - 6). Their speed and end position can be adapted as required.

The SwitchPilot Familie

If requested, the pulse signal can be disabled when the end position of the lever is reached. Furthermore, the power supply to each servo can be interrupted to prevent any "twitching" of some cheaper servos. Due to the integral DCC RailCom® - transmitter it is possible to provide status feedback of the accessory to the command station. For instance an ESU ECoS command station can then display the manually activated change of status.

Of course the transistor outputs of SwitchPilot are electronically protected against overload and short circuit.

5.1.3. SwitchPilot Extension

For operating motor drives for turnouts or for the polarization of the frogs you require a relay with potential free contacts. For this purpose each SwitchPilot can be connected to a SwitchPilot Extension which can be plugged into the side of the SwitchPilot and receive its power from it.

Each SwitchPilot Extension module has 4 by 2 relay outputs that are operated in parallel to the corresponding outputs of the SwitchPilot. This corresponds to the established k84-solution.

5.2. Features

5.2.1. Operational modes

All SwitchPilots are multi protocol capable and therefore can either be operated with command stations as per the Märklin®-Motorola® system (e.g.: 6021, Central Station®) or with DCC compliant command stations. For this SwitchPilot decoders must be contacted with solenoid accessory addresses.



Therefore, operation with the Lokmaus 2 is not possible. The Lokmaus 2 does not send DCC commands to solenoid devices.

The SwitchPilot has a switch to select different operating modes. Thus you can easily set the desired mode. Therefore "programming" is not necessary for most standard applications.



This switch only operates the four transistor output pairs 1 to 4. The servo outputs are not affected.



The operating mode switch is only for the use with Motorola control units to enable compatibility with Märklin controllers. If the SwitchPilot is used with the DCC protocol the operating mode switch needs to stay at the middle position (factory default).

5.2.1.1. k83 mode

When you push the slide into the k83 position then the outputs 1 to 4 will be switched to pulse operation regardless of the programmed settings. The SwitchPilot behaves exactly like a Märklin® k83. Use this mode whenever you want to operate conventional solenoid drives.

5.2.1.2. k84 mode

In the k84-mode the outputs 1 to 4 will be set to variable regardless of any pre-programmed settings. The SwitchPilot behaves exactly like a Märklin® k84. Use this mode to operate LEDs or light bulbs and whenever you do not require any specific programming.



All consumer loads are directly electrified by the SwitchPilot. You must not connect any external voltage!

5.2.1.3. User mode

The user mode is switched on by setting the switch for selecting the operating mode into the centre position. Only in this mode the outputs 1 to 4 will behave according to the software controlled settings. This is the correct use to DCC format, k83 and k84-Mode are only meant for Motorola® command stations.

5.2.2. Transistor outputs

The SwitchPilot has a total of 8 transistor outputs that are grouped in four pairs 1 to 4. Each pair has two outputs, OutA and OutB. There are also two separate servo outputs.

The transistor outputs can be set to continuous, to pulsed power or to alternating blinking.

Pulsed output:

If the output is set to pulse operation it will be activated as soon as a command is received. At the same time a timer starts counting: the “on-time” (duration of pulse) is determined by a pre-programmed value. The output cannot be active for longer or shorter than this value. Should you let go of the button before the end of the first pulse then the output remains active until the pre-determined time has been reached. If you press the button longer than the pre-determined pulse duration then the output is switched off even though the button is still pressed.

The limitation of the pulse duration helps avoid damage to solenoids.

The pulse duration can be set in such a way that the outputs are active as long as the button on the control panel is pressed. This operating mode is compatible with Märklin® k83 decoders.

Variable:

Pressing the appropriate button on the control panel (e.g.: “red” for Märklin® central units or „+” for Lenz Digital Plus®) switches on the first output **OutA**. It remains on until the corresponding button for output **OutB** is activated. **OutA** and **OutB** work like a change over switch.



Logically this operating mode complies with the Märklin® k84 decoder. From every output EITHER **OutA** OR **OutB** is active. Both cannot be switched at the same time!

Alternating blinker:

In this mode the terminals **OutA** and **OutB** of an output will be activated alternately. This is quite useful for the blinking red lights at level crossings amongst others.

The “on-time” can be set in the same fashion as the pulse duration.



Subject to the pulse duration and also in continuous mode it may happen that several outputs are on at the same time. Please note that the total current of all connected loads must not exceed the total permitted load of the decoder, namely 3.0 A.

5.2.3. Servo outputs

RC-servos can be connected to the SwitchPilot decoders. Compared to gear motors, servos are intelligent actuators with integrated intelligence which can move to the self-desired position and can also hold this state. In doing so, they force a different angle and speed. Will leverage against a force out, it controls the servo with all force against the angle constantly striving it should have to keep.

The nominal position will be set by a pulse line (orange on Graupner® servos, otherwise white). A constant voltage (4.8 V - 6V) completes the interface.

On the pulse line the servo expects in a time interval of 20 – 25ms a positive impulse with a length between 1.0ms and 2.0ms. The length of the pulse is directly proportional to the desired target position.

Servos are available in various designs and sizes. They differ also in the gear box and actuator angle. There are, for example, servos to make wind sail adjustment, which makes several revolutions.



Never try to turn the lever by hand as the motor of the servo can be destroyed!

5.2.3.1. Conventional servos

On conventional servos, power to the motor is applied only when a pulse signal is received. If the servo does not receive a signal, it follows the mechanical forces on the lever.

In the case that such servos show “twitching” even after reaching the end position, disabling the pulse signal will solve the problem. However it may happen that they twitch again after re-applying the signal.

5.2.3.2. Digital servos

Inside each digital servo, a microcontroller makes sure that the motor tries to reach any desired position even when no external pulse signal is received. These servos may also twitch at end positions because they try to force against the lever all the time. To prevent this, the user needs to interrupt the servo's power supply. However, it may happen that when re-applying the power, the servo may twitch again.

5.2.3.3. ESU servo motor

ESU offers two different versions of servo motors: 51804 uses a plastic gearing, 51805 is equipped with metal gears. These servos are equipped with a microcontroller that is optimized for the use in model railroad environment. It prevents any twitching at all times. In addition, ESU supplies a lot of accessories such as levers, mounting brackets and screws for a convenient installation

5.2.4. Feedback inputs

Through RailCom® the SwitchPilot can send the current turnout position back to the digital control unit. For this the turnout needs to have the corresponding feedback contacts which must be connected to feedback contact input **FB A** and/or **FB B** (see Figure 6 for details).

6. Connection to the digital system



We recommend setting all parameters of the SwitchPilot prior to installing the unit on your layout.

6.1. Connecting elements of the SwitchPilot

Figure 1 shows the SwitchPilot

- Wire turnouts, signals, un-couplers or similar devices to the terminals of the (transistor) outputs 1 to 4. The terminals FB A and FB B are used for status feedback of the device.
- This multi-pin connector serves to wire two commercially available RC-Servos (e. g.: Graupner®, Futaba® or ESU) and represents the outputs 5 and 6 of the SwitchPilot.
- The power supply for the SwitchPilot and all the devices connected to it are wired to the terminals Pw A und Pw B. We recommend a filtered DC power supply (such as ESU 50119) as well as the digital track voltage can be used.
- The screw terminals Trk A and Trk B connect the SwitchPilot with the power output of a command station (e.g. booster output) transmitting the digital commands.
- The switch controlling the operating modes allows you to select any of the supported modes such as k83, user mode and k84-mode (also compare with chapter 5.2.1).
- The LED „PROG“ in conjunction with the
- programming button helps you to set the digital address of the SwitchPilot. This process is described in chapter 7.
- Power-LED: This is on once power is supplied to the decoder.
- The extension socket / plug connect the SwitchPilot and the SwitchPilot Extension mechanically and electrically.
- Decoder ground – needed for manual turnout operation
- Monitor-LED for Output OutA: Lits when the output is active
- Monitor-LED for Output OutB: Lits when the output is active

Connection to the digital system

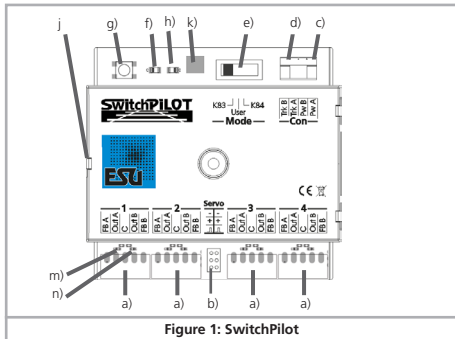

Figure 1: SwitchPilot

6.2. Power supply from the digital system

For smaller layouts with only a few devices to be switched simultaneously the power supply of the digital system may be used.

The screw terminals **Pw A** and **Pw B** are wired in parallel to the terminal **Trk A** and **Trk B**.



Depending on the used solenoid devices the digital control unit might not be able to supply enough current for a safe operation. In this case an external transformer which can supply enough current for these solenoid devices needs to be connected to the SwitchPilot.



When using certain solenoid devices (i.e. Märklin® K track turnouts or PECO® motors) you should consider an external supply of SwitchPilot).

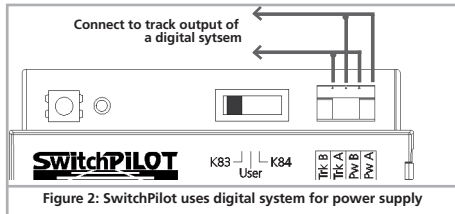

Figure 2: SwitchPilot uses digital system for power supply

6.3. Separate power supply

For larger layouts with many devices controlled by SwitchPilots and simultaneously active we recommend to utilise a separate power supply; in this manner the power for switching the devices is not drawn from the track and thus reduces the load on the digital system.



Only use commercially available equipment designed for model trains and also take note of the maximum voltage as stated in chapter 15 in order to avoid any potential damage.



This way of connecting cannot be used for programming on the programming track, compare chapter 7.2.1.

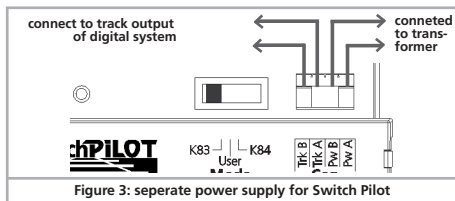

Figure 3: separate power supply for Switch Pilot

Transistor outputs

6.4. Wiring of transistor outputs

6.4.1. Connecting double-coil solenoids

You may use all commercially available double-coil solenoid drives by all major manufacturers with SwitchPilot.

Figure 4 shows how to wire output 1:

- The common wire of the solenoid is wired to screw terminal Out C.
- The wire leading to the first coil is connected to terminal Out A.
- The wire leading to the second coil is connected to terminal Out B.

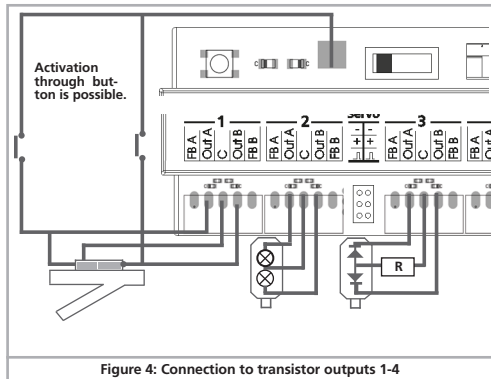

Figure 4: Connection to transistor outputs 1-4

i Should the aspect shown on your control panel not be as desired (in other words: if straight and diverging route are exchanged) simply swap the wires between terminals Out A and Out B.

i SwitchPilot can also handle PECO® turnouts. However, their current consumption is so high that you must adjust the overload setting of the SwitchPilot. Please refer to chapter 9.3. for details.

i As shown in Figure 4 the double-coil turnouts can be switched with two optional push buttons without a digital command. The needed ground solder pad is not available on all SwitchPilot surfaces.

6.4.2. Wiring daylight signals and light bulbs or LEDs

If you use daylight signals with incandescent lamps (light bulbs) or LEDs you must set the corresponding output to continuous mode.

If the signal has incandescent lamps as shown for output 2 in figure 5 you may wire the lamps directly to the terminals of the SwitchPilot.

In order to limit the current for signals with LEDs a resistor must be wired in series with the LEDs. This is shown for output 3 in figure 5.

! Please check if your signal already has a built-in resistor. Applying power without this resistor will destroy the LEDs immediately!

If there is no resistor in place you must wire this resistor marked "R" in series to the LEDs. Subject to the supply voltage and the desired brightness of the signal the resistor should have a rating of about 1 kohm to 2.2 kohm.

i The screw terminal C of each output has positive potential. Therefore the cathode of the LEDs must be connected to the terminals Out A respectively Out B.

Wiring a servo

6.5. Wiring a servo

All commercially available RC-servos for hobby applications may be used. They must have a three-pole terminal and operate on a positive pulse. The SwitchPilot provides 5V to the servo.

Simply insert the wire from the servo into the appropriate socket of the SwitchPilot. Generally the white or orange wire is used for the pulsed outputs of the servo.



Please refer to the wiring diagrams on the housing of the SwitchPilot. Incorrect connections may destroy either the servo or the SwitchPilot!

The servo outputs can be configured individually as you can see in chapter 10.

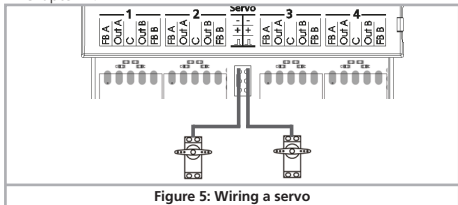

Figure 5: Wiring a servo

6.6. Wiring feedback contacts

The SwitchPilot can report the actual aspect or position of the turnout to the command station via RailCom®. The turnout must have some extra contacts for this. Figure 6 illustrates this situation:

- a) Connecting a motor of a turnout with limit stop contacts. Connect the terminals **Out A** with **FB A** and **Out B** with **FB B**.
- b) Connecting a motor with separate feedback contacts: connect the feedback contacts with terminal **FB A** respectively **FB B** and the common wire of the feedback contacts to terminal C.



How the status (feedback) is displayed depends on your command station. The ESU ECos®-command station can display the status on the turnout control panel.

Further information about feedback of switches via RailCom® can be found in chapter 11.

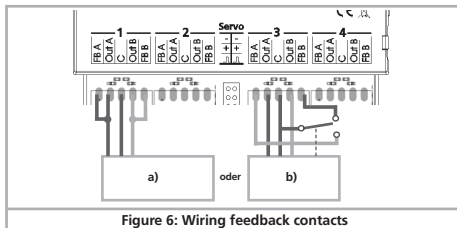

Figure 6: Wiring feedback contacts



Connection of SwitchPilot Extension

6.6. Wiring the SwitchPilot Extension

The SwitchPilot Extension module is connected by inserting it into the multi-pin connectors on the side of the SwitchPilot; push until the retaining clips make positive contact. The internal logic and relays of the SwitchPilot Extension module receive power from the SwitchPilot.

6.6.1. Relay outputs

Figure 7 to the left shows the connections.

- a) Outputs 1 through 4 each offer a relay output A and B which are switched together (DPDT, bi-stable). Each relay output corresponds with the transistor output of the SwitchPilot or the servo output of the SwitchPilot Servo: If output **Out A** is active (or servo setting A is reached) the terminals **I** and **Com** of the relay output are connected. Is output **Out B** on the SwitchPilot active (or servo setting B is reached) the terminals **II** and **Com** are connected.

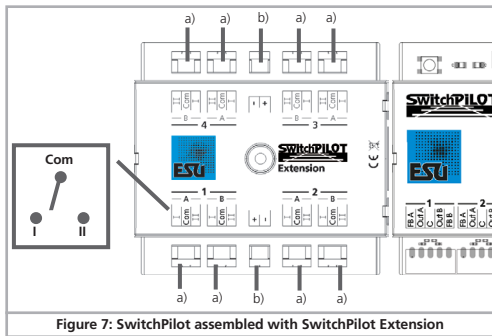

Figure 7: SwitchPilot assembled with SwitchPilot Extension

- b) Terminal with ground and voltage power (U+) DC for the use of DC turnout motors like the Tortoise motor.

6.6.2. Wiring a motor drive

The SwitchPilot can operate motor drives for turnouts with the help of the SwitchPilot Extension. The direction of the motor is reversed by changing the polarity of the voltage on the motor terminals thus changing the position of the turnout or the aspect of a semaphore signal.



Only use motor drives with limit stop contacts to avoid overheating or a burnout of the motor. The relay outputs of the SwitchPilot Extension always connect the supply voltage to the load.

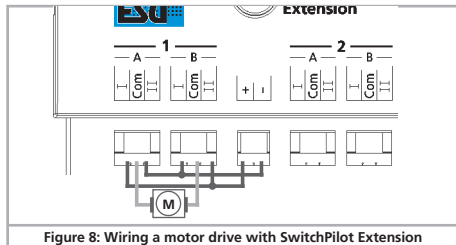

Figure 8: Wiring a motor drive with SwitchPilot Extension

A motor drive is wired as shown in figure 7. It will be energized by the SwitchPilot.

Please take note of the permitted maximum supply voltage of your motor drive as stated in its manual.

6.6.3. LGB® motor drive

You may connect a LGB® motor drive as shown in figure 9. If the settings have not been changed otherwise, the motors will be supplied for about 250 ms and turned off after to avoid any damage due to excess heating.

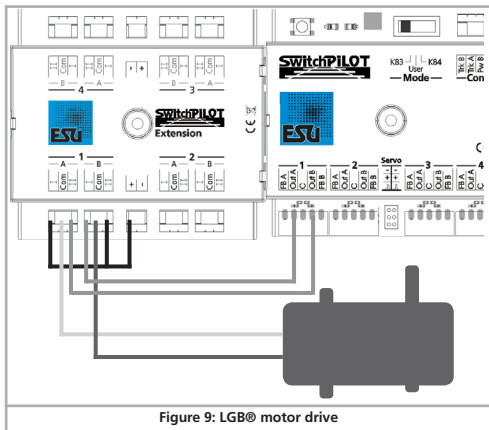

6.6.4. Polarizing electric frogs

You may polarize (supply power of the correct polarity) to the electro-frog of your turnout.

If you would like to use a servo with your turnout it is most often necessary to choose the exact timing in such a way that the relays only switches when the servo is positioned in the middle between setting A and B. This way shorts are being prevented. See Chapter 12.1. for more details.

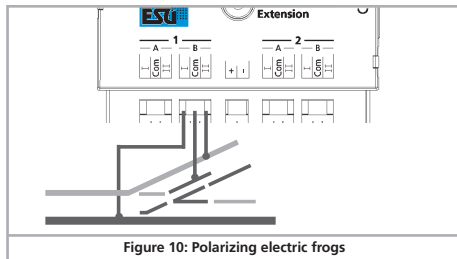

Decoder settings (programming)

7. Decoder settings (programming)

Chapter 7 is about changing the settings of the SwitchPilot decoder. In case you are not familiar with the CVs please take some time to read through the sometimes very complex explanations.

After an introduction into the world of parameters in Chapter 7.1, Chapter 7.2 explains how to change the parameters with different DCC control units.

Chapters 8 through 11 explain which parameters influence the behavior of the SwitchPilot decoder

7.1. Changeable decoder settings

Certain capabilities of the SwitchPilot decoder like the amount of function outputs or the maximum current load are physically limited through hardware and are not changeable. However, there are still plenty of possibilities to change the behavior of the SwitchPilot decoder through software changes.

For each individual parameter there are one or more storage locations within the decoder in which numbers or letters can be stored. You can think of these storage locations as index cards which are kept in a large file cabinet. In order to find the individual index cards each one has a number or description with the property of the card, e.g. „Loco Address“ or „Maximum Speed“. Now imagine that those cards can be written on with a pencil; changes are always possible through erasing and writing. Not all „cards“ can be written on. Certain pieces of information like the manufacturer identification for ESU are hardcoded.

The content of these storage locations can be chosen by you and is being read and considered by the decoder. You can fill the storage locations with any value through a procedure that is also known as programming.

7.1.1. Configuration Variables (CV)

All SwitchPilot decoders follow the CV concept which was developed in the United States. The name CV (Configuration Variable) is derived from the fact that the memory cells being described above are not only variable but can also configure the behavior of the decoder.

7.1.1.1. Standardization regarding NMRA

The NMRA (National Model Railroad Association) has specified which CV controls what function in a decoder. The DCC norm describes the CVs with numbers whereby the most important ones are given. Thereby the handling of CVs is simplified for the user since decoders of many manufacturers follow this standardization and the learned handling of CVs can be applied everywhere. Within the DCC CV concept number values between 0 and 255 can be written into CVs. Each CV consists of exactly one number.



While the position (CV number) has been predetermined the actual range of values can vary. Not all CVs need to accept values between 0 and 255. Allowed values for the SwitchPilot decoder are shown in the list in Chapter 20.

7.1.1.2. Bits und Bytes

Most CVs contain numerical values: CV 8 for example contains the manufacturer's identification. This one can range from 1 to 255. Other CVs can be understood as a collection point of different switches which together control different functions (most often turning on or off). Good examples are CVs 28 and 29: The intended value for this CV needs to be calculated. This value depends on the desired parameter. Take a look at the table in Chapter 17 and its description for CV34: First decide which option needs to be turned on or off. In the value column are two numbers for each option. If the option is turned off the value is set 0, otherwise a number between 1 and 8. Add those two numerical values for this specific option and you will get the value which needs to be written into the CV.

Decoder settings (programming)

Example:

Assuming you would like to activate the SwitchPilot's „zoom“ function on outputs 1 and 3, the value of CV 34 needs to be set 5 ($1 + 0 + 4 + 0 = 5$).

7.2. Programming with DCC systems

SwitchPilot decoders understand all programming methods of the NMRA, so in addition to the programming track modes (Direct Mode, Register Mode, Page Mode) also the main track programming „POM“ (programming on the main).

With POM you can comfortably program your decoder without having to take your locomotive off the track. For this the central unit must contact the decoder with its specific address, for example: „Decoder 10, write value 1 into CV 3“. The decoder address must be known. The reading of CV values is not possible in this case.



It is possible to read out CVs on the main track with RailCom®. More information can be found in chapter 11.

CV values can be read and set on the programming track – a suitable DCC system provided. Furthermore you can program decoders on the programming track without knowing the decoder address since the central unit uses commands like „Write value 1 to CV3!“ Each decoder that receives this command will also execute it.



ESU counts the bits from 0 to 7 as specified in the DCC norm while some manufacturers (e.g. Lenz) count the bits from 1 to 8. Please keep this in mind when programming our decoders with such systems.

7.2.1. Programming on the programming track

For programming specific parameters of the decoder outputs the SwitchPilot has to be programmed on the programming track. This is most practical prior to installation on the layout.

7.2.1.2. Connecting to the programming track

For programming please connect the SwitchPilot as shown in figure 11 to your digital system. In this instance the power must be supplied from the command station.

The SwitchPilot „understands“ all relevant DCC programming modes. It is best to program it in DCC Direct Mode.



In order to be able to read out any data you must connect a load to output 1 Out A that draws more than 60 mA, for instance a light bulb or a 180 Ohm / 1 Watt resistor.

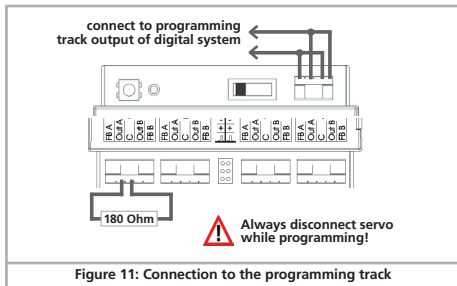

Figure 11: Connection to the programming track

The reading of CVs should function with all DCC conformal central units and was tested with ESU ECoS, Bachmann® Dynamis ProBox®, Uhlenbrock® Intellibox® and Lenz® Digital Plus V3®. Unfortunately,

Digitrax® units do not supply enough current on the programming output, ZIMO® units sometimes report an over current. Therefore, use the main track programming 7.2.2.

7.2.2. Programming on the main track

The SwitchPilot can remain installed on your layout during the programming. In order for the main track programming to work your digital system must also understand „Programming on the Main: (POM) for solenoid devices. In addition you must know the decoder address of your SwitchPilot decoder.

Please make sure to carefully read Chapter 8 so you understand the difference between turnout number and decoder address.

Thanks to the built-in RailCom® technology, ECoS owners can program the SwitchPilot while it is installed on the layout. More can be found in chapter 11.

7.3. Programming with Märklin® central stations

A direct programming possibility with a Märklin central unit (e.g. 6021, Mobile Station®, Central Station®) is not possible due to the missing DCC format. However, the most important properties can still be changed.

The desired turnout numbers can be set directly with buttons. Chapter 8.4 has more information. By means of the operating mode switch you can choose between k83 or k84 mode (find more 5.2.1).

For all options we recommend the use of the ESU Lokprogramer.

7.4. Programming with the ESU LokProgrammer

Owners of the ESU LokProgrammer device are able to set up the SwitchPilot decoders very comfortably. Please always use the latest computer software. It can be downloaded from our website without any charge. The LokProgrammer will occasionally update the firmware. Connect your SwitchPilot as shown in fig. 12 to make sure everything works as expected.

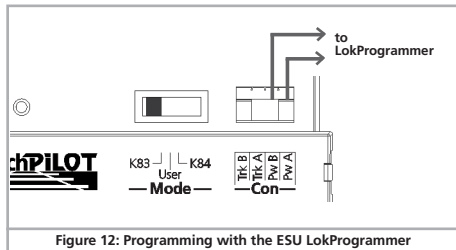

Figure 12: Programming with the ESU LokProgrammer

8. Address settings

The numbers of the outputs of the SwitchPilot can be assigned freely – within limits. Unfortunately, the DCC norm is not comprehensible that easily so therefore we would like to explain it here in detail and also have you very thoroughly work through Chapter 8 in case you are not yet familiar with it.

8.1. Turnout numbers

The outputs of the SwitchPilot are numbered:

- The SwitchPilot offers a total of 6 outputs: Outputs 1 through 4 are double transistor outputs, outputs 5 through 6 are servo outputs.

All available turnouts are numbered in all DCC or Märklin® digital systems. The number of available turnout numbers is limited:

Motorola®: Turnout numbers 1 – 256

DCC: Turnout numbers 1 – 2040 Servo outputs:

All turnout numbers are summarized by addresses. Turnouts 1 – 4 form the first address, turnouts 5 – 8 the second one, etc.

In order to function properly each SwitchPilot must know the address that is assigned to it.

Since the SwitchPilot has a total of six outputs two addresses can be assigned to it: address 1 is responsible for the transistor outputs 1 – 4, address 2 is for the servo outputs 5 – 6.



This logic means that the outputs (and therefore the turnout numbers) of the SwitchPilot always start at the beginning of an address on one hand, and that all outputs stay together in one block on the other hand.

8.2. Decoder address

The desired address is divided internally and put into CV 1 and CV 9. Please never mix up decoder address and the turnout number resulting from it.

Most digital systems (incl. the ECoS) show the turnout numbers instead of the decoder addresses on the control panels.

The second turnout address for the servo outputs 5 - 6 of the SwitchPilot is stored in CV 35 and CV 36.

8.2.1. Schedule of turnout numbers and addresses

The relation between turnout numbers and turnout addresses is explained in the table starting on page 17: The desired turnout numbers are derived from the chosen turnout address. Only the first 256 turnouts are accessible when using Motorola® central units.



It is not possible to assign turnout numbers above the limit of 4 to a SwitchPilot. For example, it would not be possible to assign turnout numbers 4, 5, 6, or 7 to a SwitchPilot servo since those are above the address limit. Please keep this in mind when numbering your turnouts.



The table only shows the first 552 turnout numbers. 2040 turnouts are possible in DCC operation. A complete table can be found on our web site.

Turnout number				Address	CV1	CV9
1	2	3	4	1	1	0
5	6	7	8	2	2	0
9	10	11	12	3	3	0
13	14	15	16	4	4	0
17	18	19	20	5	5	0
21	22	23	24	6	6	0
25	26	27	28	7	7	0
29	30	31	32	8	8	0
33	34	35	36	9	9	0
37	38	39	40	10	10	0

Turnout number, addresses & CVs of the first 552 turnouts

Turnout number				Address	CV1	CV9
41	42	43	44	11	11	0
45	46	47	48	12	12	0
49	50	51	52	13	13	0
53	54	55	56	14	14	0
57	58	59	60	15	15	0
61	62	63	64	16	16	0
65	66	67	68	17	17	0
69	70	71	72	18	18	0
73	74	75	76	19	19	0
77	78	79	80	20	20	0
81	82	83	84	21	21	0
85	86	87	88	22	22	0
89	90	91	92	23	23	0
93	94	95	96	24	24	0
97	98	99	100	25	25	0
101	102	103	104	26	26	0
105	106	107	108	27	27	0
109	110	111	112	28	28	0
113	114	115	116	29	29	0
117	118	119	120	30	30	0
121	122	123	124	31	31	0
125	126	127	128	32	32	0
129	130	131	132	33	33	0
133	134	135	136	34	34	0
137	138	139	140	35	35	0
141	142	143	144	36	36	0
145	146	147	148	37	37	0
149	150	151	152	38	38	0
153	154	155	156	39	39	0
157	158	159	160	40	40	0
161	162	163	164	41	41	0
165	166	167	168	42	42	0

Turnout number				Address	CV1	CV9
169	170	171	172	43	43	0
173	174	175	176	44	44	0
177	178	179	180	45	45	0
181	182	183	184	46	46	0
185	186	187	188	47	47	0
189	190	191	192	48	48	0
193	194	195	196	49	49	0
197	198	199	200	50	50	0
201	202	203	204	51	51	0
205	206	207	208	52	52	0
209	210	211	212	53	53	0
213	214	215	216	54	54	0
217	218	219	220	55	55	0
221	222	223	224	56	56	0
225	226	227	228	57	57	0
229	230	231	232	58	58	0
233	234	235	236	59	59	0
237	238	239	240	60	60	0
241	242	243	244	61	61	0
245	246	247	248	62	62	0
249	250	251	252	63	63	0
253	254	255	256	64	0	1
257	258	259	260	65	1	1
261	262	263	264	66	2	1
265	266	267	268	67	3	1
269	270	271	272	68	4	1
273	274	275	276	69	5	1
277	278	279	280	70	6	1
281	282	283	284	71	7	1
285	286	287	288	72	8	1
289	290	291	292	73	9	1
293	294	295	296	74	10	1
297	298	299	300	75	11	1

Turnout number, addresses & CVs of the first 552 turnouts

Turnout number				Address	CV1	CV9
301	302	303	304	76	12	1
305	306	307	308	77	13	1
309	310	311	312	78	14	1
313	314	315	316	79	15	1
317	318	319	320	80	16	1
321	322	323	324	81	17	1
325	326	327	328	82	18	1
329	330	331	332	83	19	1
333	334	335	336	84	20	1
337	338	339	340	85	21	1
341	342	343	344	86	22	1
345	346	347	348	87	23	1
349	350	351	352	88	24	1
353	354	355	356	89	25	1
357	358	359	360	90	26	1
361	362	363	364	91	27	1
365	366	367	368	92	28	1
369	370	371	372	93	29	1
373	374	375	376	94	30	1
377	378	379	380	95	31	1
381	382	383	384	96	32	1
385	386	387	388	97	33	1
389	390	391	392	98	34	1
393	394	395	396	99	35	1
397	398	399	400	100	36	1
401	402	403	404	101	37	1
405	406	407	408	102	38	1
409	410	411	412	103	39	1
413	414	415	416	104	40	1
417	418	419	420	105	41	1
421	422	423	424	106	42	1
425	426	427	428	107	43	1
429	430	431	432	108	44	1

Turnout number				Address	CV1	CV9
433	434	435	436	109	45	1
437	438	439	440	110	46	1
441	442	443	444	111	47	1
445	446	447	448	112	48	1
449	450	451	452	113	49	1
453	454	455	456	114	50	1
457	458	459	460	115	51	1
461	462	463	464	116	52	1
465	466	467	468	117	53	1
469	470	471	472	118	54	1
473	474	475	476	119	55	1
477	478	479	480	120	56	1
481	482	483	484	121	57	1
485	486	487	488	122	58	1
489	490	491	492	123	59	1
493	494	495	496	124	60	1
497	498	499	500	125	61	1
501	502	503	504	126	62	1
505	506	507	508	127	63	1
509	510	511	512	128	0	2
513	514	515	516	129	1	2
517	518	519	520	130	2	2
521	522	523	524	131	3	2
525	526	527	528	132	4	2
529	530	531	532	133	5	2
533	534	535	536	134	6	2
537	538	539	540	135	7	2
541	542	543	544	136	8	2
545	546	547	548	137	9	2
549	550	551	552	138	10	2

Factory settings

8.3. Factory settings

The four transistor outputs 1 to 4 react ex works to the turnout numbers 1 to 4 with all outputs set to single pulse mode with 520 msec pulse duration. Address „1“ belongs to the SwitchPilot. The servo outputs 5 – 6 are deactivated ex works. There is no second address to be allocated.

8.4. Programming addresses with the programming button

You may program the addresses with the help of the programming button without any complicated procedure on the programming track. We recommend to proceed as follows:



You must use this method if you work with a Märklin® Motorola® central unit (6021, Central Station®) or if you want to change the addresses of the turnouts after installation of the decoder on your layout.

8.4.1. First address for outputs 1 – 4

1. Select the turnout number on your digital system that you want to assign to the first output of your SwitchPilot. Proceed as per the instructions of your handheld throttle or your command station as if you wanted to switch the respective turnout (for ECoS users: refer to chapter 13 in the ECoS manual).
2. Turn on the power supply of your layout.
3. Press the programming button and hold it long enough until (after about two seconds) the LED blinks as follows: short, pause, short, pause, and so on.
4. You may now release the button, the decoder is in learning mode.
5. Now switch the turnout you have selected in step 1 on your handheld controller or your command station. It is immaterial whether you switch from “straight” to “diverging route” or vice versa.
6. Once the decoder has “understood” the address it will confirm this by lighting up the LED for one second.
7. Then the SwitchPilot goes back to the normal operating mode and the LED extinguishes.

Should you have programmed another turnout instead of the first one of the group of four the correct group will be automatically detected and programmed.

8.4.2. Second address for outputs 5 - 6

The second address is used for the (servo) outputs 5 and 6. Always select turnout numbers at the beginning of a group of four, e.g.: 1 and 2, 5 and 6, 9 and 10, 13 and 14, etc.

1. Select the turnout number with your digital system that you would like to assign to output 5 (first servo). Proceed as per the instructions of your handheld controller or your command station as if you wanted to switch this particular turnout
2. Turn on the power for your layout.
3. Press the programming button and hold it down until (after about four seconds) the LED blinks as follows: short, short, pause, short, short, pause, and so on.
4. Then you may release the button; the decoder is now in learning mode.
5. Switch the turnout you have selected in step 1 with your hand held or the command station. It is immaterial if you switch from “straight” to “diverging route” or vice versa.
6. If the decoder has “understood” the address it confirms this by the LED lighting up for about one second.
7. The SwitchPilot then goes back to the normal operating mode and the LED extinguishes.

9. Parameters of the transistor outputs

In order to set the parameters of the transistor outputs 1 to 4 each is assigned to a configuration-CV: CV 3 is responsible for output 1, CV 4 for output 2, CV 5 for output 3 and CV 6 for output 4.

9.1. Configuration of an output with variable duration (k83)

Write the value 0 in the appropriate CV. The output will then behave as follows: the output is active as long as the corresponding button on the control panel is pressed. Once you release the button the output will switch off immediately. This is useful for uncouplers amongst others.

9.2. Output configuration to pulsed output with fixed pulse duration

Write a value between 2 and 31 into the configuration-CV if you wish the output to generate a pulse of a pre-determined duration regardless of how long you actually press the button. This value describes the duration of the on-period as a multiple of 65 msec. The higher this value, the longer is the on-period.

Example:

You want to have an output lasting about one second. Write the value 15 into the CV ($16 * 65 \text{ msec} = 975 \text{ msec}$)

9.3. Configuration of an output for PECO solenoid drives



If you wire a PECO solenoid drive to an output write the value 1 into the corresponding configuration-CV. This adjusts the overload (over current) protection to the higher values for PECO solenoid drives.

If you would like to use PECO turnout motors you have to use an external transformer to supply the SwitchPilot with enough current. See section 6.4.

9.4. Configuration of an output for continuous operation (k84)

If you wish to alternately activate one of the transistor outputs until the other one is switched on then write the value 64 into the configuration-CV.

9.5. Configuring the „zoom“-effect

The lights of prototype daylighting signals do not come on within a split second but rather take a few moments until they reach full output respectively until they extinguish fully. This effect can be simulated by programming the “zoom“- function to each output in CV 34. Please refer to the table in chapter 17.

10. Features of servo outputs

Two end positions “A” and “B” as well as a turning speed can be assigned to each servo output.

You can also define when the pulse signal is sent to the servo and if power should be interrupted on certain occasions.

If your digital command station supports programming on the Main (POM) you may fine tune these CVs in normal operating mode. Change the settings of the relevant CVs step by step until the servo reaches the desired end position.

10.1. Configuration of servo end position „A“

The end position „A“ of the servo can be set in CV 38 and 41. The precise value depends on the type of servo and the installation. This can only be established by experimenting.

10.2. Configuration of servo end position „B“

The end position „B“ of the servo can be set in CV 39 and 42. The precise value depends on the type of servo and the installation. This can only be established by experimenting.

10.3. Configuration of servo speed

For each one of the servo outputs you can set the running time of the servo from point A to B to model prototypical motions.

The CVs 37 and 40 are responsible for this. Possible values range from 0 to 63 as a multiple of 0.25 sec. For example, the servo takes about $15 * 0.25 = 3.75$ seconds to reach the other end position at the factory default setting of 15.

Higher values may lead to a slower movement and may cause the servo to jerk or stutter since it cannot keep up very low revolutions at a constant speed. In this case reduce the value or use a servo with a different gear ratio and slower movement. Of course, the SwitchPilot cannot change the mechanical properties of the servo.

10.4. Disabling the pulse signal and power supply

To avoid “twitching” of conventional servos you can disable the pulse signal being sent to the servo after it reaches the end position. Further you can set the power supply to each individual servo be interrupted after it reaches the end position. You may refer to CV 50 to do these settings.

Bit	Description
0	Initial impulse after command received: If set, then the pulse signal will be sent to the servo only after first command is given to the servo.
1	Timeout impulse after position reached: After the servo reaches the end position, the signal is turned off.
2	Power on servo only while moving: The power supply to the servo is interrupted usually and enabled only while the servo should be moving

11. RailCom®

RailCom® is a technology which was developed by the company Lenz Elektronik, Giessen for transmitting information from the decoder back to the digital control unit. The past DCC system could only transmit data from the control unit to the decoder but could never verify whether the data actually arrived or not.

The following information can be sent from the SwitchPilot decoder to the central unit:

CV Information: The decoder can return all CV values to the central unit via RailCom®. A programming track will not be necessary in the future.



11.1. How to activate RailCom®

All SwitchPilot decoders are capable of using Railcom®. It is disabled by factory default and can be enabled as follows:

Set CV 29 Bit 3.

Set CV 28 Bit 1.



The first time the Railcom® function is being enabled it should be done on the programming track (see sections 7 and 8). After Railcom® has been turned on you can directly continue with the other programming steps.

11.2. How to read out CVs with RailCom® and ESU ECoS

After a successful Railcom® activation you can directly read CVs from the main track – as long as this is being supported by your central unit. The approach to do this for the ESU ECoS is displayed here. In our example a decoder which is configured for turnout numbers 13 – 16 needs to be read. The turnout numbers 13 – 16 correspond to decoder address 4.

- Go to the general programming menu of the ECoS
- Choose „Main Track Programming, „DCC“, and then „Solenoid Accessories“
- Enter the decoder address of the SwitchPilot on the bottom right. In our example, this is number 4.
- Enter the number of the CV that you would like to read in the CV field
- Press the „Read“ button
- The read value must be displayed immediately.

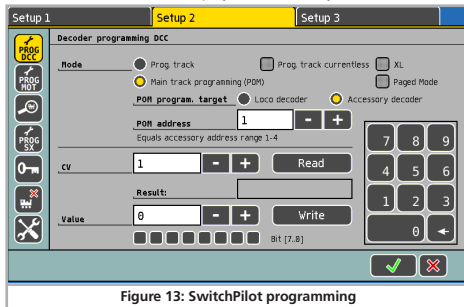

Figure 13: SwitchPilot programming

11.3. Feedback of turnout position with the ECoS

As mentioned in section 5.2.5 the current position of a turnout can be displayed at the ECoS at any time. In our example, a turnout with the number 14 needs to be set up in the ECoS. Proceed as follows:

- Go to the menu „New Solenoid Device“
- Under data format choose „DCC with RailCom®“
- Choose the desired symbol and enter the turnout number (in our case 14)
- Now connect the solenoid device with a control panel as described in the ECoS manual in section 13.3.
- If the current setting does not coincide with the desired setting, it will be indicated with a small exclamation mark.

Depending on the setup of your feedback modules it might be possible that feedback lines are switched. If you do not want to rewire those you can simply check the box „Swap SwitchPilot Feedback“.

If the SwitchPilot has not yet been programmed for turnout numbers 13 – 16 you can now continue as shown in section 8.

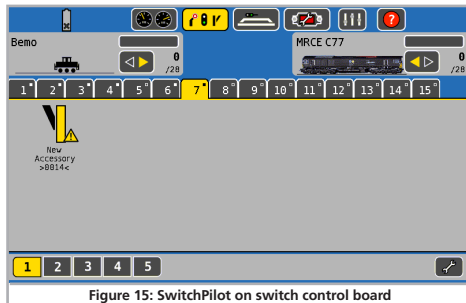

Figure 15: SwitchPilot on switch control board

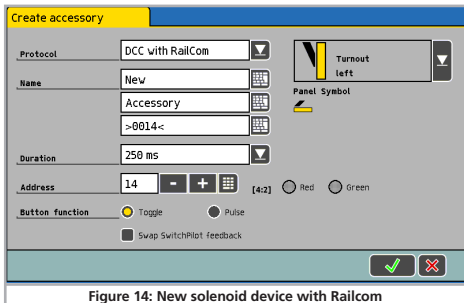

Figure 14: New solenoid device with Railcom

12. Options for SwitchPilot Extension

The behavior of an optional SwitchPilot Extension module can be modified with CV 49.

12.1. Time of switching

Normally the relays of the SwitchPilot Extension module switch immediately after receiving the command. But this can lead to a short at the frog polarization because the turnout tongue remains at the previous position for a while. The behavior can be changed in such a way that the relays only switch in the middle between positions A and B. The exact switching point of the relays depends on the desired switching time of the servo.

12.2. Assignment of Relays

The relays of the SwitchPilot Extension module switch together with transistor outputs 1 – 4 by factory default. In a few cases you might want to switch the relays together with servo outputs 5 – 6 (e.g. for frog polarization). Therefore, it is possible with CV 49 to assign the secondary address (servo outputs 5 – 6) to each relay output.

Example:

You would like to operate relay outputs 1 and 2 together with servo outputs 5 – 6 but relay outputs 3 and 4 should be switched in parallel to transistor outputs 3 – 4. Therefore, write the value 3 into CV 49. As soon as you want to switch the relay outputs together with the servo outputs the time of switching will be delayed automatically.

13. Decoder reset

You can reset to the factory defaults at any time:

13.1. With DCC systems

Write value 08 into CV 08.

Please keep in mind that the reading of CV 08 will show the value 151 (manufacturer ID of ESU). Writing the value 8 to CV 8 is a special case. Therefore, a few central units show „err02“ or similar errors. However, the SwitchPilot still accepts the command.

13.2. With programming button

- Disconnect the power to the SwitchPilot decoder
- Press and hold the programming button at the SwitchPilot
- Reconnect the power to the SwitchPilot. The decoder will be reset to factory defaults.
- Release the programming button.



15.3. With ESU LokProgrammer

In the menu „Edit CVs“, option „Read/Write CVs“ write the value 08 into CV 08.

16. Support and assistance

Your model train dealer or hobby shop is your competent partner for all questions regarding your SwitchPilot decoder. In fact he is your competent partner for all questions around model trains.

Of course, you may also contact us directly. For enquiries please use either email or fax (don't forget to provide your own fax-no. or email address) and we will reply within a few days.

Please call our hotline only in case of complex enquiries that can't be dealt with by email or fax. The hotline is often very busy and you may encounter delays. Rather send an email or fax and also check our website for more information. You will find many hints under "Support / FAQ" and even feedback from other users that may help you with your particular question.

Of course we will always assist you; please contact us at:

Contact Germany:

Phone : ++49 (0) 731 - 1 84 78 - 106
(Tue&Wed 10am -12am)
Fax : ++49 (0) 731 - 1 84 78 - 299
E-Mail: www.esu.eu/kontakt
Warranty address: ESU GmbH & Co. KG
- Technical Support -
Edisonallee 29
D-89231 Neu-Ulm

www.esu.eu

15. Technical data

15.1. Technical data SwitchPilot V2.0

Operating modes:

- NMRA/DCC „Accessory Decoder“ compatible. Address range from 1 - 2044
- Märklin® Motorola® compatible, up to turnout number 384. k83 compatible. k84 logic
- Power supply by digital command station or separate DC-power supply.
- Maximum supply voltage: 18V AC or 24V smooth DC.
- Transistor outputs 1 to 4:
- 4 outputs with two transistors each, each with 1.5A continuous, 2.0A peak (20 seconds).
- Total maximum load of device: 2.0A continuous, 3.0A peak (20 seconds)
- Overload and short circuit protection for outputs.
- Switching time of each output between 0.06 sec to 2.00 sec or adjustable for variable. Optional blinking mode and „zoom“-effect for lighting effects.
- Servo outputs:
- 2 Servo outputs for RC-servos (e.g.: Graupner® JR, Futaba® or ESU), adjustable pulse duration between 1.0 msec and 2.0 msec, positive pulse. Adjustable speed and end positions.
- Power supply for the servos with 5V stabilised supply. Maximum current draw of the servo: 250 mA continuous, 500 mA peak (20 seconds)
- Feed back:
- ntegral RailCom® status feedback reports turnout status via the tracks and can be displayed on ECoS (amongst others).
- Dimensions in mm:
- app. 86mm x 86mm x 25mm

15.2. Technical data SwitchPilot Extension

Operating modes:

- Extension module for SwitchPilot, power is supplied by the latter. Relay outputs are controlled by SwitchPilot.

Outputs:

- 4 Relays with two outputs each (2 x changers), switched as one, with screw terminals for potential-free switching or power supply for electro-frogs.
- Maximum load per relay output: 30V AC, 2 A continuous.

Dimensions in mm:

- app. 86mm x 86mm x 25mm

List of all supported CVs

20. List of all supported CVs

CV	Name	Description	Range	Value		
1	Decoder address 1, LSB	Lower 6 bits (bit 0 - 5) of the first decoder address for the outputs 1 to 4. Is used in conjunction with CV 9 in order to store the address	1 - 63	1		
3	Configuration output 1 (only SwitchPilot!)	Describes the properties of decoder output 1.		0 - 64	8	
		Function	Description			Value
		Variable	k83-compatible: output is active as long as the button at the control panel is pressed.			0
		Pulse mode PECO	pulse mode for PECO-turnout drives. Reduces the sensitivity of the overload protection			1
		Pulse mode	Duration of „On“-status: multiple of 65 msec.			2 - 31
		Alternating	Out A and Out B are alternately active blinker. Duration of „On“-status: multiple of 130 msec.			32 - 63
Bi-stable	k84-compatible: either Out A or Out B is active, variable.	64				
4	Configuration output 2 (only SwitchPilot!)	Describes the properties of decoder output 2		0 - 64	8	
		Function	Description			Value
		- as CV 3 -				
5	Configuration output 3 (only SwitchPilot!)	Describes the properties of decoder output 3.		0 - 64	8	
		Function	Description			Value
		- as CV 3 -				
6	Configuration output 4 (only SwitchPilot!)	Describes the properties of decoder output 4.		0 - 64	8	
		Function	Description			Value
		- as CV 3 -				
7	Version number	Interne Softwareversion des Decoders (SwitchPilot: 115, SwitchPilot Servo: 153)	115/153			
8	Manufacturer's ID	Manufacturer's ID by ESU. Writing value 8 results in a full factory reset of all CVs.	-	151		

List of all supported CVs

CV	Name	Description	Range	Value		
9	Decoder address 1, MSB	higher 3 bits (bit 6 - 8) of the first decoder address for the outputs 1 to 4. Used together with CV 1 to store the address.	0 - 7	0		
28	RailCom® configuration	Activation and configuration of RailCom-functions	0,2	0		
		Bit			Description	Value
		1			Data transfer on channel 2 No data transfer on channel 2 Data transfer on channel 2 permitted	0 2
29	Configuration register	DCC-configuration settings for SwitchPilot	128	128		
		Bit	Description	Value		
		3	RailCom® communication			
			RailCom® communication is switched off	0		
			RailCom® communication is permitted	8		
7	Decoder is DCC Accessory Decoder (read only, cannot be reprogramed)	128				
33	Function output status	Current status of function outputs 1 to 4.	0 - 255	-		
		The status of the 8 feedback contacts is only valid if they are wired correctly to the turnout feedback contacts. The value of CV 33 can be read and displayed via RailCom®.				
		Bit			Description	Value
		0			Status output 1, input FB A	1
		1			Status output 1, input FB B	2
		2			Status output 2, input FB A	4
		3			Status output 2, input FB B	8
		4			Status output 3, input FB A	16
		5			Status output 3, input FB B	32
		6			Status output 4, input FB A	64
7	Status output 4, input FB B	128				

List of all supported CVs

CV	Name	Description	Range	Value
34	„Zoom“-configuration	Defining the outputs 1 - 4 that should show the „fade-in, fade-out“ effect when turned on or off. „Zoom“ means slow fade-in or fade-out of the function. This enables you to simulate the prototypical changeover of daylight signals, hence this function only makes sense for daylight signals.	0 - 15	0 - 15
		Bit	Beschreibung	Wert
		0	„Zoom“-function active for output 1	1
		1	„Zoom“-function active for output 2	2
		2	„Zoom“-function active for output 3	4
3	„Zoom“-function active for output 4	8		
35	Decoder address 2, LSB	Lower 6 bits (bit 0 - 5) of the second decoder address for the outputs 5 and 6. Is used in conjunction with CV 36 in order to store the address.	1-63	1
36	Decoder address 2, MSB	Higher 3 bits (bit 6 - 8) of the second decoder address for the outputs 5 and 6. Is used in conjunction with CV 35 in order to store the address. Value 8 in CV36 switches off the second address (factory setting)	0 - 8	8
37	Servo 1, rotation speed	Running time (speed) of servo 1 from one end position to the following. The running time is always a multiple of 0.25 seconds: 1 = 0.25s,...,63 = 15.75s	0 - 63	15
38	Servo 1, Position „A“	Position A of Servo 1. Value indicates the pulse duration transmitted to the Servo. Value 0 = 1msec,..., 63 = 2msec.	0 - 63	24
39	Servo 1, Position „B“	Position B of Servo 1. Value indicates the pulse duration transmitted to the Servo. Value 0 = 1ms,..., 63 = 2ms.	0 - 63	40
40	Servo 2 rotation speed	like CV 37	0 - 63	15
41	Servo 2, Position „A“	like CV 38	0 - 63	24
42	Servo 2, Position „B“	like CV 39	0 - 63	40

List of all supported CVs

CV	Name	Description	Range	Value		
49	Relay control (only with SwitchPilot Extension) (Details in chapter 12)	Configuration, which relay is to be switched decelerated.	0 - 15	SPS: 15 SP: 0		
		If Bit active, relay switches between „A“ and „B“.				
		Bit			Description	Value
		0			Relay 1 decelerated switch (addit. SwitchPilot: Switches with 2nd addr.)	1
		1			Relay 2 decelerated switch (addit. SwitchPilot: Switches with 2nd addr.)	2
2	reserved	4				
3	reserved	8				
50	Impuls-Configuration	Defines how the pulse signale is applied to the servo	0-7	0		
		Bit			Description	Value
		0			Initial pulse signal after command received	1
		1			Timeout impulse after position reached	2
2	Power on servo only while moving	4				

Warranty certificate

Warranty certificate

Dear customer,

Congratulations on purchasing this ESU product. This quality product was manufactured applying the most advanced production methods and processes and was subject to stringent quality checks and tests. Therefore ESU electronic solutions ulm GmbH & Co. KG grants you a warranty for the purchase of ESU products that far exceeds the national warranty as governed by legislation in your country and beyond the warranty from your authorised ESU dealer.

ESU grants an extended manufacturer's warranty of 24 months from date of purchase.

Warranty conditions:

- This warranty is valid for all ESU products that have been purchased from an authorised ESU dealer.
- No claims will be accepted without proof of purchase. The filled in warranty certificate together with the receipt from your ESU dealer serves as proof of purchase. We recommend keeping the warranty certificate together with the receipt.
- In case of a claim please fill in the enclosed fault description as detailed and precise as possible and return it with your faulty product.

Extend of warranty / exclusions:

This warranty covers free of charge repair or replacement of the faulty part, provided the failure is demonstrably due to faulty design, manufacturing, material or transport. Please use the appropriate postage stamps when shipping the decoder to ESU. Any further claims are excluded.

The warranty expires:

1. In case of wear and tear due to normal use.
2. In case of conversions of ESU – products with parts not approved by the manufacturer.
3. In case of modification of parts, particularly missing shrink sleeves, or wires directly extended on the decoder.
4. In case of inappropriate use (different to the intended use as specified by the manufacturer).
5. If the instructions as laid down in the user manual by ESU electronic solutions ulm GmbH & Co. KG were not adhered to.

You may submit your warranty claims either at your dealer or by shipping the product in question with the warranty certificate, the receipt of purchase and the fault description directly to ESU electronic solutions ulm GmbH & Co. KG to:

ESU GmbH & Co. KG
- Warranty department -
Edisonallee 29
D-89231 Neu-Ulm

Trouble Shooting Sheet

1. Personal Information

(Please use block letters)

Name: _____
Street: _____
ZIP code/ city: | | | | |
Country: _____
E-Mail: _____
Telephone: _____
Date: _____
Signature: _____

2. Error class

- | | |
|---|---|
| <input type="checkbox"/> Transistor outputs 1-4 | <input type="checkbox"/> Short circuit |
| <input type="checkbox"/> Servo outputs | <input type="checkbox"/> Dead On Arrival, no function right out the box |
| <input type="checkbox"/> No function anymore | <input type="checkbox"/> Programming on programming track |

3. Error description

4. Receipt of pay

Please return the goods with an invoice or receipt! Otherwise no warranty!

5. Additional Information:

6. Your retailer:

Retailer's stamp or address

